

# ***NQi***





The SN Code of your scooter.  
Please see P.6 for detailed information.

# CONTENTS

General Notice	01
Precautions	02
Safety Notice	03
Installation Guide	04
Downloading the App	06
Parts Info	07
Dashboard Display Info	09
Operation Guide	12
Battery Use and Maintenance Guide	17
DOs and DON'Ts while Riding	22
Maintenance and Repair	24
Storage Methods	26
Regular Maintenance Checklist	27
Technical Parameters	33
Warranty Information	36
Service and Maintenance	38
Maintenance Record	40

## General Notice

- Please read this User Manual carefully for proper operation before riding the scooter.
- For your safety, please check whether the parts are in good condition according to this User Manual before riding. Contact your dealer in time in case of any problems.
- Please follow the traffic laws. Slow down on slippery roads in bad weather to allow greater braking distance for your safety.
- Please pay attention to deep water. It may cause rusting or failure of the motor, battery, or other parts if water level reaches wheel axle.
- Do not dismantle the scooter on your own. Please contact your dealer for replacement or purchase of original parts.
- For others' safety and preventing unnecessary damage to your scooter, do not lend your scooter to those who can't operate.
- Please keep the User Manual properly. The final explanation of this User Manual belongs to the manufacturer and is subject to change without notice.
- For more product information or maintenance need, please visit our website: [www.niu.com](http://www.niu.com)

## Precautions

- Rider and Passenger  
**This scooter is not designed for a ride of more than 2 person.**
- Road Conditions  
This vehicle is not designed for off-road use.
- This User Manual should be deemed as a permanent document of This scooter. If this scooter is transferred to others, this User Manual should also be handed over to the new owner.
- Reproduction or reprint of any part of this User Manual is strictly prohibited.

**⚠ ATTENTION:** Do not exceed speed limit and apply brakes cautiously. Always use side stand or central stand when parking.

**⚠ WARNING:** Failure to follow the instructions herein may lead to personal injury or scooter damage.

## Safety Notice

- Using a helmet and protective goggles is strongly advised.
- You are advised to take proper training or exercise before using on open roads.
- Please follow the Operation Guide to fully understand how to properly operate the scooter.
- It should be noted that the braking distance in bad weather will be much longer. Please avoid braking on paint markers, manhole covers, and oil stains to prevent slipping. Pay extra attention when riding through railway crossings, junctions, tunnels, and bridges. Slow down if road conditions are unclear.
- Do not use high beam indiscriminately. Continuous use of high beam may disturb the vision of other drivers and pedestrians.
- Do not use mobile phones or other electronic devices which may draw your attention while riding.
- Do not change the lane without signaling. Changing the lane at will is one of the major causes for accidents. When you need to change the lane, remember to switch on the Turn Signal Indicator first. Always check the vehicles approaching from behind before changing the lane.

## Installation Guide

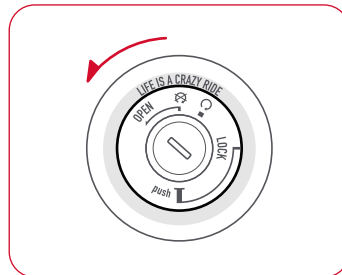

- Step 1** Insert the key to the main lock and turn to the icon of "OPEN" as shown in the right figure.

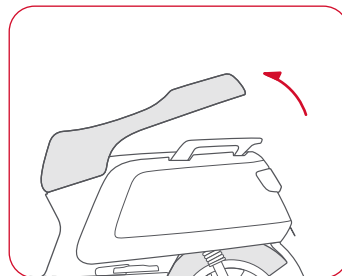

- Step 2** Open the saddle to take out the key box, windshield package (with rubber pads and standard parts), and installation tools.

Insert the key into the keyhole in the rear storage and turn it to open the battery compartment. Take out the charger and rearview mirrors package inside.

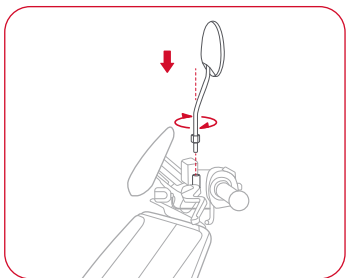

**Step 3** Take out the rearview mirrors and check them carefully. Install the left rearview mirror into the mounting hole on the left brake lever and turn it clockwise. The bolt shall be screwed in for more than 15 mm.

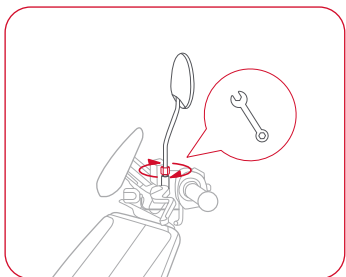

**Step 4** Adjust the rearview mirrors to an appropriate position and then tighten nuts on the rearview mirror with a spanner. Properly set the dust cover. Install the right rearview mirror in the same way.

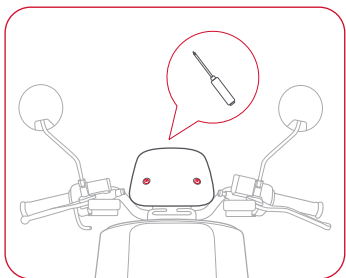

**Step 5** Align the windshield rubber part with the windshield holes and then install it. Tighten the two screws with the screwdriver to secure the windshield.

## Downloading the APP

Functions such as checking battery level, locating, and management can be implemented on the electric scooter through the app.

**Step 1** Scan the QR code below to download the APP titled Niu E-Scooter.



**Step 2** Run Setup after downloading and register.

**Step 3** Please scan the QR code on the inside of cover page for app registration.

### **NOTE:**

The mobile phone system is required to be at least Android 4.0 or iOS 8. Make sure that the mobile phone has been connected to the Internet when running the app (Wi-Fi / 2G / 3G / 4G).

# Parts Info

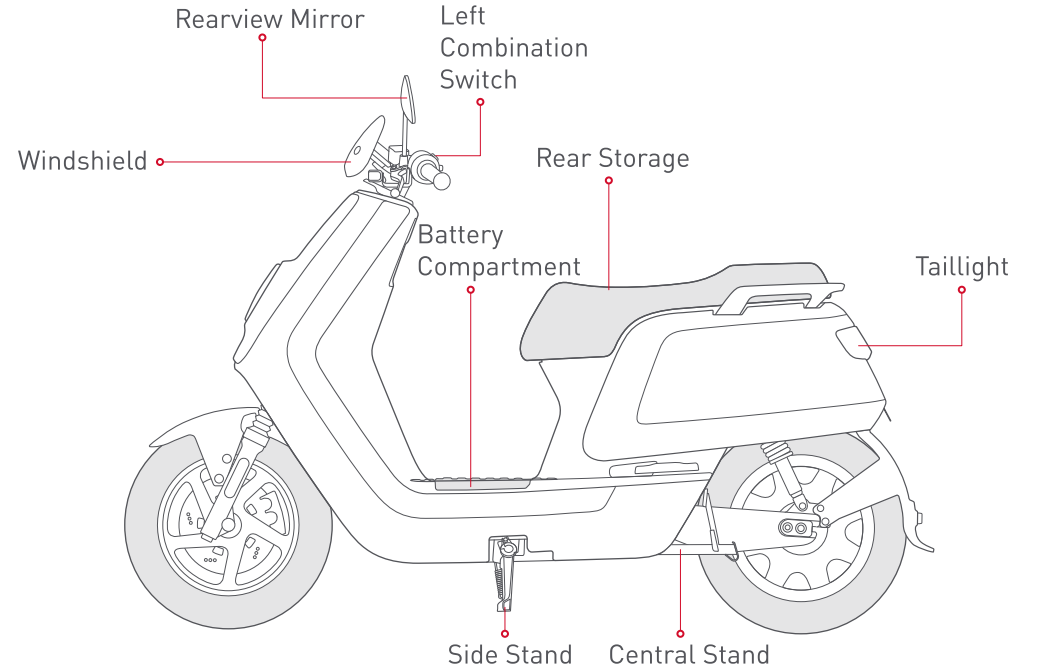
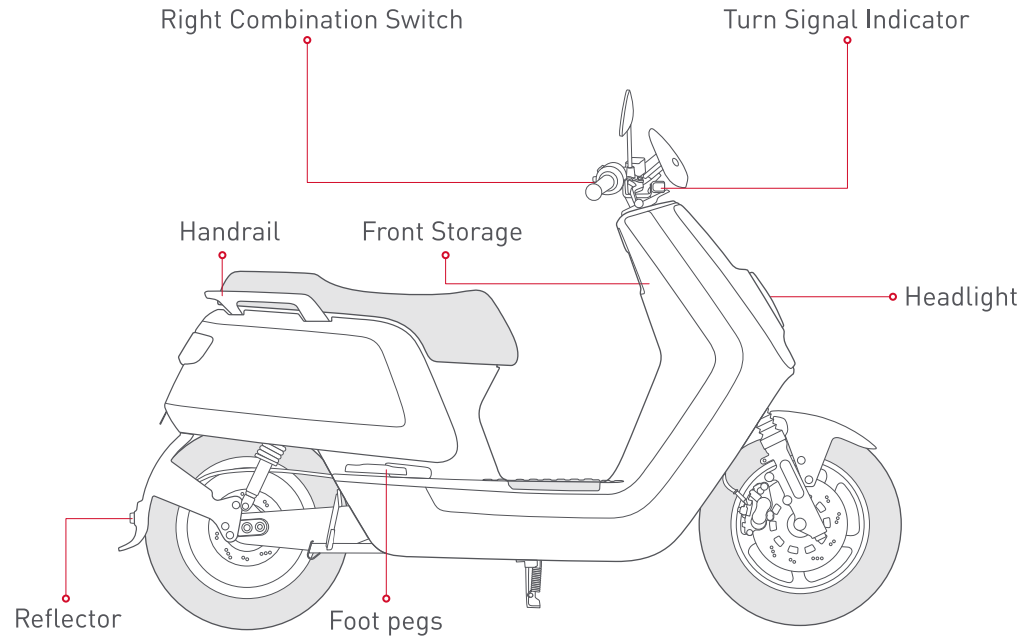

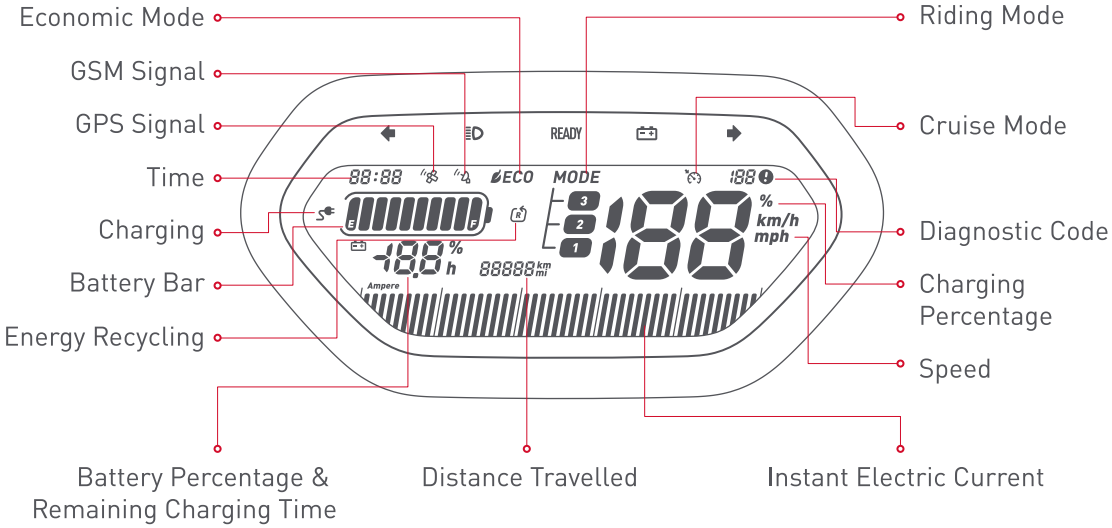

# Dashboard Display Info

- ← Left Turn Indicator
- READY Ready Indicator
- Right Turn Indicator
- HD High Beam
- Low Battery Indicator



←	Left Turn Indicator	The Left Turn Indicator is on.
→	Right Turn Indicator	The Right Turn Indicator is on.
HD	High Beam	The High Beam is on.
READY	Ready Indicator	In Riding Mode.
🔋	Low Battery Indicator	Battery level less than 10%.
10:00	Time	Now is 10:00
ECO	Economic Mode	Ideal energy consumption status.
📶	GPS Signal	No flashing: Signal strong. Bars are falshing: Signal weak.
📶	GSM Signal	Entire icon flashing: No signal.
🏍️	Cruise Mode	The scooter is in Cruise Mode.
30	Diagnostic Code	The Diagnostic Code is 30. Please see the "Troubleshooting List"
ER	Energy Recycling Status	Energy is being recycled from braking.
🔋	Battery Bar	Current battery level is 80~89%.

<b>85%</b>	Battery Percentage (Small)	Current battery level is 85%.
<b>- 3.2h</b>	Remaining Charging Time	The remaining charging time is 3.2 h (using scooter charging port).
<b>S</b>	Charging	Battery is being charged.
<b>00802mi</b>	Distance Travelled	Distance Travelled is 802 miles.
	Instant Electric Current	Indicates instant power output.
<b>MODE</b> 	Riding Mode	Mode 2 is selected.
<b>26<sup>mph</sup></b>	Speed	Current speed is 26 mph.
<b>13%</b>	Charging Percentage (Large)	Current battery charging progress is 13% (using scooter charging port).

## Operation Guide

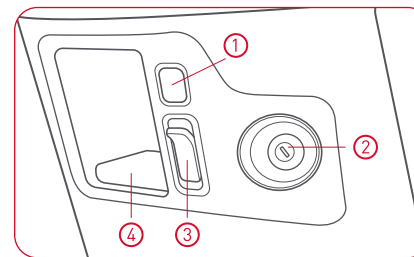

### Front Storage Area

- ① USB Charging Port
- ② Main Lock
- ③ Hook
- ④ Front Storage

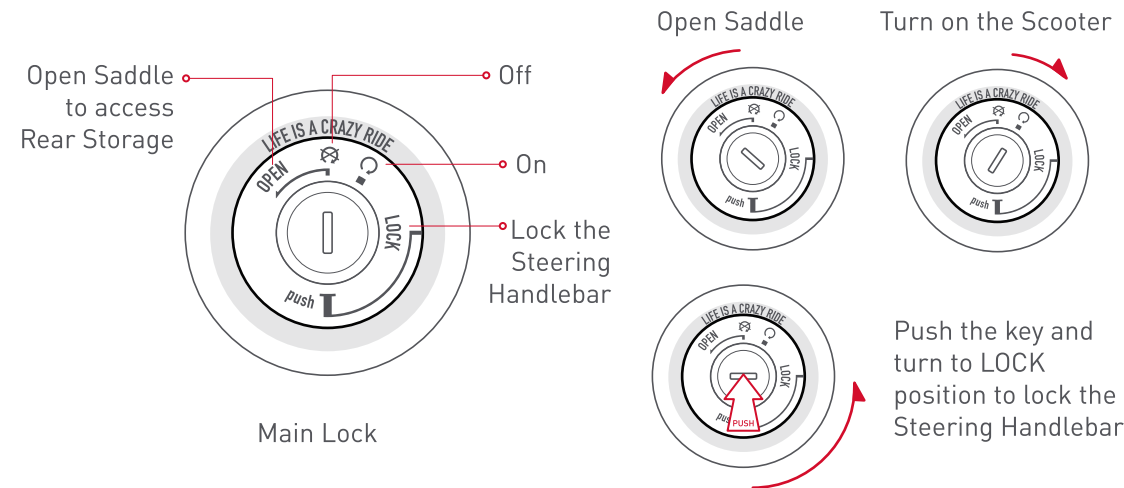



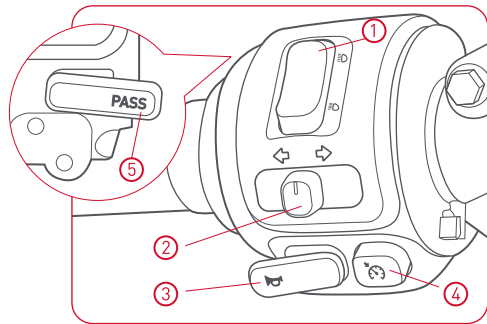

### Left Combination Switch

- ① High/Low Beam Light
- ② Turn Signal Indicator
- ③ Horn
- ④ Cruise Mode switch
- ⑤ Overtaking Light Button

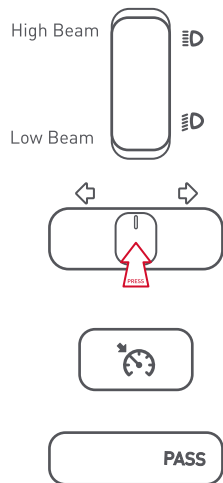

**High/Low Beam Light:** Press the upper part to switch to high beam; press the lower part to switch to low beam.

**Turn Signal Indicator:** Push the button left to turn on the Left Turn Signal Indicator; push the button right to turn on the Right Turn Signal Indicator. Press the button to turn off.

**Cruising Mode:** Push the button to cruise at current speed. Press again or brake to turn it off.

**Overtaking Light Button:** To signal overtaking with flashing light, the rider may press and release the Overtaking Light Button repeatedly.

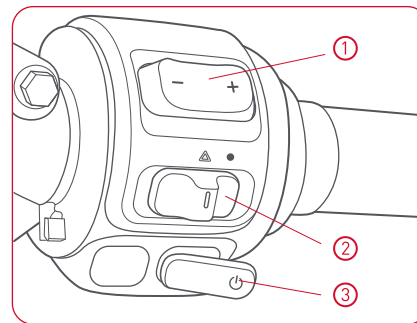

### Right Combination Switch

- ① Mode Selector
- ② Hazard Light Switch
- ③ Start/Stop Button

Switch down      Switch up



**Mode Selector:** Press right part to switch up the mode. Press left part to switch down the mode.

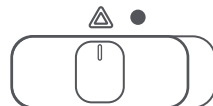

Turn on the Hazard Light



Turn off the Hazard Light

**Hazard Light Switch:** Push the switch left to turn on the Hazard light; push the switch to the left again to turn it off.



**Start/Stop Button:** Press and hold the button for 2 seconds to set the scooter in the riding mode. The **READY** indicator on the dashboard will light up and you are ready to go. Press the button again to turn it off.

## Start the Scooter

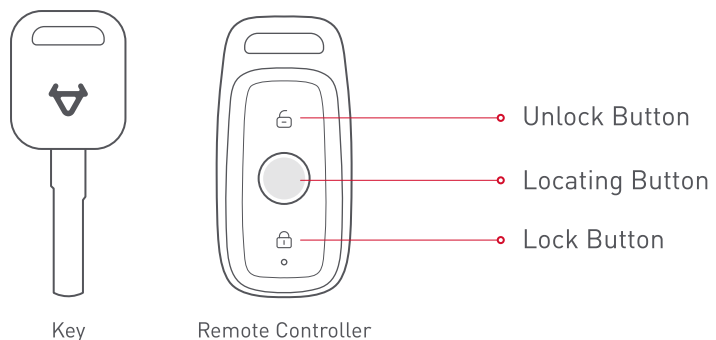

**Step 1** Press the Unlock button of the remote controller. After the Turn Signal Indicators flash twice, the scooter is unlocked.

**Step 2** After the scooter is unlocked, insert the key into the Keyhole and turn clockwise to  position.

**Step 3** After system diagnostic, hold the brake and press the Start Button for 2 seconds.

**Step 4** The **READY** indicator will light up. Release the brake and the scooter will be ready to go.

## Locking Steering Handlebar

Turn the steering handlebar to the left, then push the key inward and turn it anticlockwise to LOCK position.

## Locking with Remote Controller

The scooter can only be locked when the scooter is turned off. Press the Lock Button on the Remote Controller within an effective distance to turn on the Alarm. The Turn Signal Indicators will stay on for 2 seconds after the scooter is properly locked.

## Locating

Press the Locating Button and the Turn Signal Indicators will flash for 10 seconds. If no further operation during this period, the Alarm will be on for 10 seconds. The Alarm can be cancelled by pressing the Unlock or Lock Button.

# Battery Use and Maintenance Guide

## Using Environment

In order to prevent possible leakage, overheat, smoking, fire or explosion, please follow these instructions:

- The battery should be used at the temperature of -10°C to 45°C.
- Do not expose to water, beverages or corrosive liquids.
- Keep away from heat source, open fire, inflammable and explosive gases and liquids.
- Please keep metal parts away from the battery compartment.

In case of undesirable odor, overheat or deformation of the battery, please disuse the battery immediately, keep away from the battery and contact your dealer.

**⚠ WARNING:** The battery is not a repairable part by the user. In case of battery fault, please contact your dealer. Users dismantling the battery may lead to leakage, overheat, smoking, fire or explosion. This will invalidate product warranty.

## Charging Environment

The battery should be charged at the temperature of 10°C to 35°C. The charging time should not exceed 24 hours, or it will shorten the battery life. Do not charge the battery outdoors.

**⚠ ATTENTION:** Do not charge the battery below 0°C.

**⚠ WARNING:** Using non-original battery chargers may lead to leakage, overheat, smoking, fire or explosion.

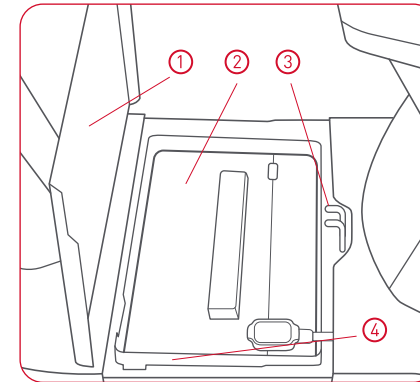

- ① Battery Compartment Cover
- ② Battery
- ③ Battery Compartment Lock
- ④ Battery Compartment

## Charging Methods

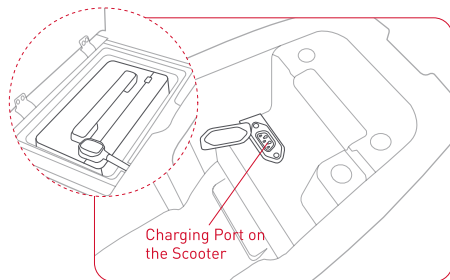

### Charging inside the Scooter

- Open the saddle with the key, plug the charging plug into the charging socket. After the charging indicator turns from green to red, charging is started.
- Turn on the scooter during charging to show the progress on the dashboard.

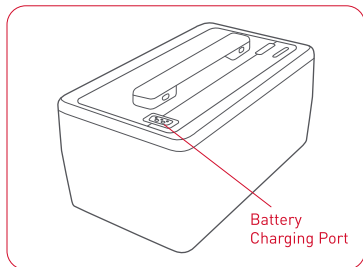

### Charging outside the Scooter

- Remove the battery from the scooter. Connect the charger with battery and socket. When the charger indicator light is red, the battery is being charged.
- After the charger indicator light turns from red to green, charging is completed.

### **WARNING**

- All operation should be strictly conform to the user manual. If not, result will be assumed by user.
- Must use original charger.
- Pay attention to the type of battery and applied voltage. Mixture use is forbidden.
- Charging should be in ventilated environment. DO NOT charge in closed space or under high temperature. DO NOT put charger into trunk or tail box while charging.
- While charging, connect battery with charger before connect with electric supply. After fully charged, disconnect the electric supply before unplug the battery plug.
- When the green light turns on, disconnect the power in time.
- Avoid long time connection between charger and AC power supply while not charging.
- While charging, if the signal light is abnormal, has odor, or the charger is over temperature, please stop charging immediately and check or change the charger in time.
- When using and storing the charger, please avoid foreign matter, especially water or other liquid in case of internal short circuit.
- DO NOT bring charger within scooter, if have to, please make sure of damping.
- DO NOT disassemble or change the parts in charger by yourself.

### **ATTENTION**

- If the battery can not be fully charged after 12 hours, please stop charging and contact your dealer.
- To maximize the battery life, please keep the battery percentage within 20% to 80%.
- The battery will faster lose capacity in low temperature conditions. To be more specific, the usable capacity is 70% at -10°C, 85% at 0°C and 100% at 25°C.
- The best battery capacity performance for storage is 50%.

Storing battery with less than 10% or more than 90% over along period of time will cause irreversible capacity loss to the battery.

- The battery needs to take out from the scooter for storage longer than one week. In this condition, please keep the battery at the temperature of 0°C to 20°C with capacity of 30%-70%. It's advised to have at least one cycle of charge and discharge every 2 months to minimize battery capacity loss during storage.
- If the battery failure is due to misuse or lack of proper maintenance as instructed, its warranty will be invalidated.
- Falling may cause uncontrollable internal damage to the battery and may cause leakage, overheat, smoking, fire or explosion.

## DOs and DON'Ts while Riding

### Before Riding

Please check the following details before riding.

Check Point	Description
Steering Handlebar	(1) Steadiness (2) Steering flexibility (3) No axial displacement or loosening
Braking	Braking lever has 5 to 9mm idle travel.
Tyres	(1)The air pressure range of the front tyre is 29 to 36psi; the air pressure range of the rear tyre is 33 to 36psi. (2) Proper tyre tread depth (3) No cracks or openings (4) Minimum load-capacity index: front 23, rear 49. (5) Minimum-speed category: B.
Battery	Adequate for planned distance to travel.
Lights	Check all the lights—High Beam, Low Beam, Brake Light, Turn Signal Indicator, etc.
Horn	Check whether the horn can work.

## Braking Precautions

Adjust the scooter upright before applying brakes. If the tyres are locked and the scooter loses steering ability resulting from excessive braking force, loosen the grip on the braking lever and the tyres will be working again and the scooter will be stabilized. Try to maintain a 1:1 ratio of front and rear braking force on slippery roads.

**⚠ Caution:** For your safety, do not exceed the speed limit, use the brakes gently to maintain at safe speed while riding downhill.

**⚠ ATTENTION:** Inexperienced riders tend to use the rear brake only, which will accelerate the wear of the brake and result in a longer braking distance.

**⚠ Warning:** Using the front brake or rear brake only is dangerous because of possible grip or control loss. Pay extra attention and use the brakes gently when riding on damp, slippery roads, and around corners. Otherwise, riders will be exposed to great danger.

## Maintenance and Repair

Users are advised to have the scooter checked and maintained on a regular basis, even for the scooters that are not used for a long time.

### Regular Maintenance

Maintenance work may only be carried out by an authorised workshop. In order to maintain the guarantee, maintenance must be carried out in accordance with the chapter "Service and Maintenance".

### Daily Maintenance

If any problem occurs during checks, please look through the Home Repair Instructions or send the scooter to the dealer's for checks and maintenance.

### Scooter Washing

Please always take out the battery before washing the scooter. Please use neutral detergent and water to wash the scooter. Use soft cloth to wipe the scooter after washing to prevent scratching.

### **⚠ ATTENTION**

If the scooter is frequently used in overload, high-speed, bumpy or up/downhill riding conditions, the maintenance cycle should be shortened.

For more guaranteed quality and longer service life, please use original parts, which are under normal warranty.

### **⚠ WARNING**

If incapable of repair or adjustment on his/her own, the scooter owner is advised to send the scooter to the dealer's for maintenance and adjustment for the sake of safety. Always choose a smooth surface road for repair and adjustment and unfold the central stand before repair and adjustment. If it's necessary to repair the scooter during a ride, mind the traffic.

### **⚠ WARNING**

Do not use pressure washer to wash the scooter, especially around the battery compartment. Do not flush the rear inner mudguard, where the charger, controller and other parts are installed behind. If the charging port on the scooter is wetted, please do not charge before the charger dries off. Contacting your dealer is recommended.

## Storage Method

### Short-term Storage

- Keep the scooter in flat, steady, well-ventilated and dry area.
- Charge the battery to 50% full before storage to maximize battery life.
- Avoid exposure under sunlight and rain to reduce damage or aging.

### Long-term Storage

- Remember to have a charge and a discharge at least every 2 months and charge the battery to 50% full before storage to maximize battery life.
- Charge the battery to 100% full after long-term storage.
- Check all the parts carefully to make sure that there is no problem before riding it. If there's any problem, take the scooter to your dealer for maintenance or repair.

**⚠ WARNING:** Please disconnect the battery from the scooter if the time of storage will exceed one month.

Regular Maintenance Checklist	
Regular Safety and Performance Check	Brakes
	Lights
	Horn
	Electric Parts
	Tyres
Structural Check	Lubrication
	Wheel Bearing
	Vibration Damper
	Central Stand
	Steering Bearing
Major Parts	Battery
	Main Wiring Harness
	Control System

Troubleshooting List		
Malfunction Description	Causes	Troubleshooting
No output when switched on	1. Dead battery 2. Alarm failure	1. Charge the battery. 2. Contact your dealer for professional checks.

Troubleshooting List		
Malfunction Description	Causes	Troubleshooting
Motor failure when turning the twist grip after switched on	1. Battery level is low. 2. The power off switch is enabled when pulling the brake lever. 3. The Parking Mode has not been turned off yet.	1. Charge the battery. 2. Do not pull the brake lever when twisting the twist grip. 3. Check "Start the Scooter" section of this Manual.
Battery charge failure	1. The plug of the battery not properly connected with the battery socket 2. Battery is overdischarged	1. Check whether the plug is loosened. 2. Contact your dealer for professional checks.
Malfunction Description	Causes	Troubleshooting
Dropping speed or range	1. Low battery level. 2. Under-inflation of tyres. 3. Frequent braking and overload. 4. Battery aging or normal capacity loss. 5. Low battery capacity resulting from low temperature.	1. Charge the battery. 2. Check the tyre inflation. 3. Develop good riding habits. 4. Replace the battery. 5. Normal situation.
Sudden stop during a ride	Dead battery	Charge the battery
	Identify the fault causes in reference to the Diagnostic Codes on Dashboard. Contact your dealer if the troubleshooting methods listed in this manual is not working.	



Troubleshooting List		
Malfunction Description	Causes	Troubleshooting
00 displayed	Communication failure or Dashboard failure	1.Disconnect the battery and reconnect it after 30 seconds. 2.Check whether the wires are loosened. 3.Contact your dealer for professional checks.
10 displayed	FOC Controller locked rotor	Stop the scooter and restart later.
11 displayed	FOC Controller undervoltage/overvoltage	Stop the scooter and restart later.
12 displayed	FOC Controller overcurrent	Contact your dealer for professional checks.
13 displayed	FOC Controller overtemperature	Disconnect the battery and cool it down before reuse.
20 displayed	Motor overtemperature	Stop the scooter and restart when cooled down.checks.

Troubleshooting List		
30 displayed	Battery overcharged	Turn on the headlight and hazard light to discharge until the code disappear.
31 displayed	Charging overcurrent	Stop charging the battery and check if the charger is failed.
32 displayed	Charging at low temperature	Take the battery indoor until back to normal operating temperature.
60 displayed	SIM card identification failure	Contact your dealer for professional checks.
60 displayed	SIM card identification failure	Contact your dealer for professional checks.
62 displayed	GPS module failure	Contact your dealer for professional checks.
63 displayed	GPS antenna short circuit	Contact your dealer for professional checks.
64 displayed	GPS antenna open circuit	Contact your dealer for professional checks.

Troubleshooting List		
65 displayed	ECU SN missing/incorrect	Contact your dealer for professional checks.
67 displayed	SIM card unpaid/inactivated/low signal strength	Contact your dealer for professional checks.
99 displayed	Electronic components communication failure	Contact your dealer for professional checks.
110 displayed	FOC Controller failure	Contact your dealer for professional checks.
111 displayed	1. The scooter is locked 2. FOC Controller verification failure	1. Press unlock button on the Remote. 2. Contact your dealer for professional checks.
120 displayed	Motor failure	Contact your dealer for professional checks.
130 displayed	Battery overdischarged	Charge the battery.
131 displayed	Over-current discharging	Stop the scooter and restart later.
132 displayed	Battery overtemperature	Stop riding and let battery cool down.

Troubleshooting List		
133 displayed	Battery undertemperature	Charge the battery after it reaches the operating temperature range.
140 displayed	Twist grip failure	Please check the wires of the twist grip or contact your dealer for professional checks.
161 displayed	The scooter is locked by remote command	Contact your dealer for professional checks.
190 displayed	Controller communication failure	Contact your dealer for professional checks.
191 displayed	BMS communication failure	Contact your dealer for professional checks.

# Technical Parameters

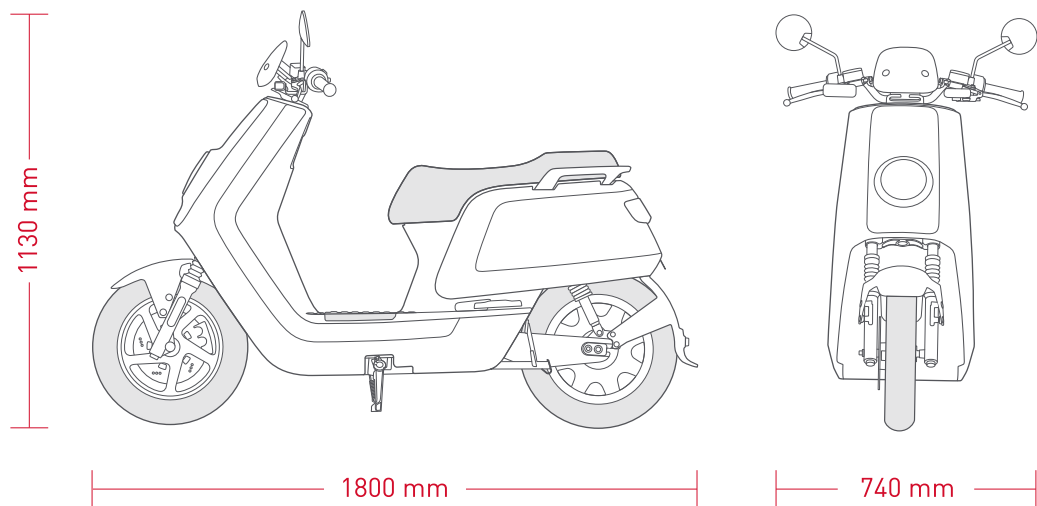

NQiSport

NQi Sport			
Features	Motor Rated Power	1500 W	
	Battery Capacity	60 V 35 Ah	60 V 26 Ah
	Max.Speed	45 km/h, 25 km/h	
	Dimension	1800 × 740 × 1130 mm	
	Product weight	89 kg	
	Maximun Load	269 kg	
	Number of seating positions	2	
	Range	60-70 km	40-50 km
	Gradeability	Dynamic: ~13°	
Battery System	Voltage	60 V	
	Standard Charging Current	4 A	
	Maximun Discharging Current	50 A, 45 A	
Electrical System	Headling/Turn/Indicator Taillight/ Brake/Light Meter Panel	12 V LED	
	Central Control Unit	12 V	
	USB Charging	5 V/1 A	
Power System	Motor	Tailored Motor by Bosch GmbH	
	Motor Control Mode	FOC Vector Control	
	FOC Controller Max.Current	45 A	

Frame	Front/Rear Dampers	Oil Damping Direct Acting Shock Absorber
	Front Tyre Specification	90/90-12 Rim:2.15×12
	Rear Tyre Specification	120/70-12 Rim:3.50×12
	Front Brake System	220 mm Dual-Piston Hydraulic Disk Brake
	Rear Brake System	180 mm Piston Hydraulic Disk Brake
	Minimum Ground Clearance	130 mm
	Seat Height	760 mm

## Warranty information

Please carefully read the instruction manual of your vehicle before operating it in order to make yourself familiar with its handling. We explicitly point out that the instruction, maintenance and care instructions given in the operating manual have to be complied with in order to sustain your claim towards warranty. Only the strict compliance with customer specifications stated in the instruction manual ensures the prolonging of the natural life of your vehicle. Starting with the date of the first handover to the end customer a limited warranty of 24 months is granted regarding the accuracy of the vehicle in terms of material and manufacturing according to latest standards. The legal warranty regulations will not be restricted by this limited guarantee. Maintenance work has to be exclusively done by authorized workshops entitled by us. Warranty in general is bound to the region of invoicing and can therefore only be carried out within the country the vehicle was bought. Damages that can be traced back to inappropriate usage, manipulation or neglecting of the maintenance/care/operating instructions will not be covered by warranty. Warranty can only be granted if occurring damages are immediately reported to the seller or any other authorized workshop by the buyer. The warranty claim entitles the buyer to remedy deficiencies or to the reparation or the exchange of a damaged part in an authorized workshop after our approval. Compensation for remote or instantaneous damages cannot be granted. Vehicles in desolate condition will not be covered by warranty. Repair works carried out on warranty do not extend the guarantee period. Only this document entitles you to call on warranty services.

Therefore please make sure that you are delivered this fully filled in document by the seller and that he has registered your vehicle correctly in our system. Please also mind the following advices. Body and panelling of the vehicle have to be kept free of dirt constantly. Do not use high pressure water blasters, strong jets of water, sharp and corrosive or other aggressive detergents which could harm surfaces and varnish permanently and foster corrosion. It is vital to use protecting cleansers. Please consult our dealers for the right and appropriate products. Aluminium parts or other refined parts (chrome parts, anodized parts or other processed surfaces) have to be treated with appropriate maintenance products in order to prevent oxidation. Frame and metal parts are continuously to be treated with anticorrosive. A vehicle constantly parked outside has to be covered to avoid weathering and crack formations on seat and plastic parts. Vehicles used off-road and for racing purposes are excluded from warranty.

Material which is to be used in the context of service and maintenance works are excluded from warranty as well as the following parts (may vary depending on vehicle):

- Lightbulbs
- Brake pads
- Wheel and axle
- Tires

## Service and Maintenance

### Important information

The date for the implementation of maintenance is the limit which is reached first. That means driven kilometer or duration since the last maintenance.

The warranty can be granted only when the vehicle was serviced in accordance with this plan and was not exposed to extraordinary stress.

Only perform appropriate works which are intended for your vehicle.

Hydraulic lines should be replaced every 4 years.

The vehicle must continuously be checked for rust. The vehicle owner is responsible for rust prevention.

On the following pages you will find the maintenance schedule and the service record.

Maintenance schedule	After the initial 1.000 km	Every 3.000 km	Every 6.000 km	Every year	Every 2 years
COMPONENT:	WHAT TO DO:				
Battery / batteries	I	I	I	I	I
Lights / switches	I	I	I	I	I
Steering bearing	I		I/C/L/A		I/C/L/A
Wheel bearing	I		I		I
Tyres	I	I	I	I	I
Rims	I	I	I		
Tight fit of all accessible bolts and nuts	I/T	I/T	I/T	I/T	I/T
Braking system	I	I	I	I	I
Brake fluid	I	I	I	I	R
Side / main stand	I/C/L	I/C/L	I/C/L		I/C/L
Telescopic fork	I		I		I
Rear shock absorber	I		I		I
Throttle grip	I	I	I	I	I
Vehicle road test	I	I	I	I	I
<p style="text-align: center;">A...Adjust      C...Clean  I...Inspect, replace or repair if defective  L...Lubricate    R...Replace    T...Tighten</p>					

## Maintenance Record

Date		Mileage	
<b>Notes:</b>			
<b>Dealer:</b>			

## Maintenance Record

Date		Mileage	
<b>Notes:</b>			
<b>Dealer:</b>			

## Maintenance Record

Date		Mileage	
<b>Notes:</b>			
<b>Dealer:</b>			

## Maintenance Record

Date		Mileage	
<b>Notes:</b>			
<b>Dealer:</b>			

## Maintenance Record

Date		Mileage	
<b>Notes:</b>			
<b>Dealer:</b>			



# Maintenance Record

Date		Mileage	
<b>Notes:</b>			
<b>Dealer:</b>			

**Distributed by:**  
KSR Group GmbH  
Im Wirtschaftspark 15  
3494 Gedersdorf  
Austria

**Imported by:**  
KSR Group GmbH  
Im Wirtschaftspark 15  
3494 Gedersdorf  
Austria

**Copyright ©2021**  
All rights reserved  
This user manual is copyrighted. Copying in mechanical,  
electronical or any other form without the written  
permission of the manufacturer is prohibited.